

Write your name here

Surname

Correchan

Other names

H. Sennet

**Pearson**

**Edexcel GCSE**

Centre Number

--	--	--	--	--

Candidate Number

--	--	--	--

# Mathematics A

**Paper 1 (Non-Calculator)**

**Higher Tier**

Monday 9 June 2014 – Morning

**Time: 1 hour 45 minutes**

Paper Reference

**1MA0/1H**

**You must have:** Ruler graduated in centimetres and millimetres, protractor, pair of compasses, pen, HB pencil, eraser. Tracing paper may be used.

Total Marks

## Instructions

- Use **black** ink or ball-point pen.
- **Fill in the boxes** at the top of this page with your name, centre number and candidate number.
- Answer **all** questions.
- Answer the questions in the spaces provided  
– *there may be more space than you need.*
- **Calculators must not be used.**



## Information

- The total mark for this paper is 100
- The marks for **each** question are shown in brackets  
– *use this as a guide as to how much time to spend on each question.*
- Questions labelled with an **asterisk** (\*) are ones where the quality of your written communication will be assessed.

## Advice

- Read each question carefully before you start to answer it.
- Keep an eye on the time.
- Try to answer every question.
- Check your answers if you have time at the end.

Turn over 

P44022A

©2014 Pearson Education Ltd.

6/5/5/



**PEARSON**

# GCSE Mathematics 1MA0

## Formulae: Higher Tier

**You must not write on this formulae page.  
Anything you write on this formulae page will gain NO credit.**

**Volume of prism = area of cross section  $\times$  length**

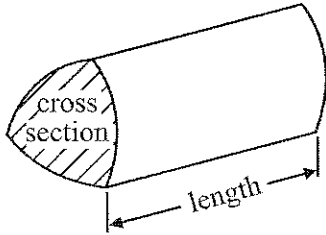

**Area of trapezium =  $\frac{1}{2} (a + b)h$**

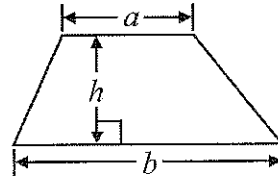

**Volume of sphere =  $\frac{4}{3} \pi r^3$**

**Surface area of sphere =  $4\pi r^2$**

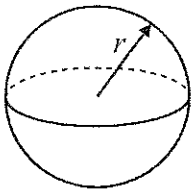

**Volume of cone =  $\frac{1}{3} \pi r^2 h$**

**Curved surface area of cone =  $\pi r l$**

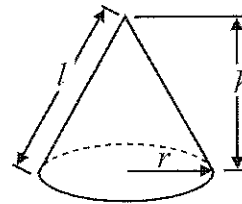

**In any triangle  $ABC$**

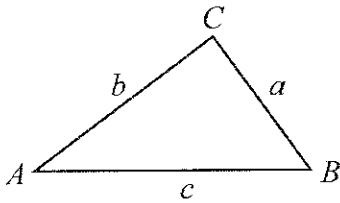

**The Quadratic Equation**

The solutions of  $ax^2 + bx + c = 0$   
where  $a \neq 0$ , are given by

$$x = \frac{-b \pm \sqrt{b^2 - 4ac}}{2a}$$

**Sine Rule  $\frac{a}{\sin A} = \frac{b}{\sin B} = \frac{c}{\sin C}$**

**Cosine Rule  $a^2 = b^2 + c^2 - 2bc \cos A$**

**Area of triangle =  $\frac{1}{2} ab \sin C$**



Answer ALL questions.

Write your answers in the spaces provided.

You must write down all stages in your working.

You must NOT use a calculator.

1 (a) Work out  $\frac{1}{7} \times \frac{2}{3}$

$$\frac{1 \times 2}{7 \times 3} = \frac{2}{21}$$

$$\frac{2}{21}$$

(1)

(b) Work out  $\frac{3}{5} - \frac{1}{3}$

$$= \frac{3 \times 3}{15} - \frac{1 \times 5}{15}$$

$$= \frac{9}{15} - \frac{5}{15} = \frac{9-5}{15}$$

$$\frac{4}{15}$$

(2)

(Total for Question 1 is 3 marks)



2 Here are the times, in minutes, that 20 children took to walk to school.

~~13~~ ~~21~~ ~~19~~ ~~27~~ ~~31~~ ~~5~~ ~~23~~ ~~29~~ ~~18~~ ~~25~~  
~~34~~ ~~15~~ ~~28~~ ~~23~~ ~~22~~ 40 16 19 32 9

Draw an ordered stem and leaf diagram for these times.

5 9 13 15 16 18 19 19  
 21 22 23 23 25 27 28 29  
 31 32 34 40

0	5	9							
1	3	5	6	8	9	9			
2	1	2	3	3	5	7	8	9	
3	1	2	4						
4	0								

Key:  
 3|2 = 32 mn

(Total for Question 2 is 3 marks)



3 50 people each did one activity at a sports centre.

Some of the people went swimming.

Some of the people played squash.

The rest of the people used the gym.

21 of the people were female.

6 of the 8 people who played squash were male.

18 of the people used the gym.

9 males went swimming.

Work out the number of females who used the gym.

This information can be presented in a 2 way table:

	Swimming	Squash	Gym	Total
Male	9	6	(14)	(29)
Female	(15)	(2)	(4)	21
	(24)	8	18	50

Number of female who used the gym is (4)

4

(Total for Question 3 is 4 marks)



4 Mr Brown and his 2 children are going to London by train.

An adult ticket costs £24

A child ticket costs £12

Mr Brown has a Family Railcard.

**Family Railcard gives**

$\frac{1}{3}$  off adult tickets

60% off child tickets

Work out the total cost of the tickets when Mr Brown uses his Family Railcard.

Cost of family Railcard

1 Adult £24

2 children  $12 \times 2 = £24$

Total £48

$$\frac{1}{3} \text{ off adult ticket} = \frac{1}{3} \times 24 = 8$$
$$\text{cost} = 24 - 8 = 16$$

Child tickets: 60% off.

$$\frac{60}{100} \times 24 = \frac{6}{10} \times 24 = \frac{3}{5} \times 24$$

$$= 72 \div 5 = £14.40$$

(or 10% of 24 = 2.40  $\therefore$  60% =  $2.40 \times 6 = 14.40$ )

$$\text{Cost} = 24 - 14.40 = 9.60$$

$$\text{Total} = \underset{\substack{\uparrow \\ \text{1 Adult}}}{16} + \underset{\substack{\uparrow \\ \text{2 children}}}{9.60} = £25.60$$

£ 25.60

(Total for Question 4 is 4 marks)



- 5 Rebecca wants to find out how many books people buy. She is going to use a questionnaire.

Design a suitable question for Rebecca to use in her questionnaire.

How many books do you buy per month?

none

1-2

3-4

5 or more

(Total for Question 5 is 2 marks)

- 6 (a) Expand  $2m(m+3)$

$$\begin{aligned} 2m \times m + 2m \times 3 \\ 2m^2 + 6m \end{aligned}$$

$$\underline{2m^2 + 6m}$$

(2)

- (b) Factorise fully  $3xy^2 - 6xy$

$$\begin{aligned} \underline{3} \underline{x} \times \underline{y} \times \underline{y} - 2 \times \underline{3} \times \underline{x} \times \underline{y} \\ 3xy(y-2) \end{aligned}$$

$$\underline{3xy(y-2)}$$

(2)

(Total for Question 6 is 3 marks)



\*7 The diagram shows the plan of a small field.

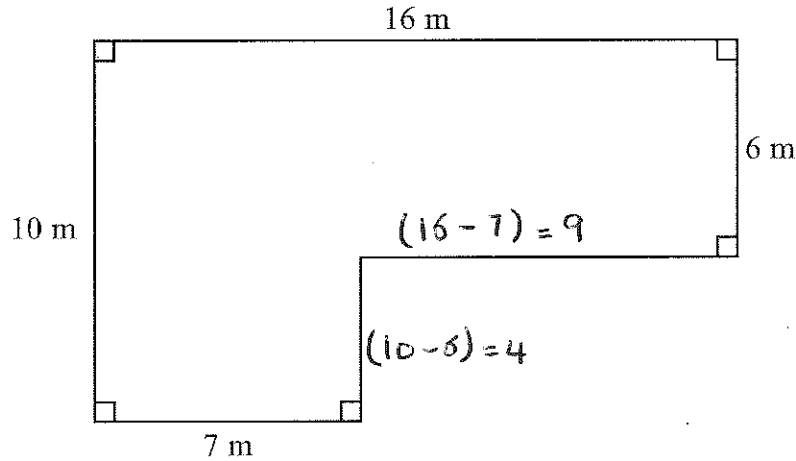

Diagram NOT accurately drawn

Kevin is going to keep some pigs in the field.  
Each pig needs an area of 36 square metres.

Work out the greatest number of pigs Kevin can keep in the field.

$$\begin{aligned} \text{Area of small field} &= 10 \left[ \begin{array}{|c|} \hline 16 \\ \hline \end{array} \right] - \left[ \begin{array}{|c|} \hline 9 \\ \hline \end{array} \right] 4 \\ &= 160 - 36 \\ &= 124 \text{ m}^2 \end{aligned}$$

1 pig occupies  $36 \text{ m}^2 \therefore$

$$\text{Number of pigs} = 124 \div 36$$

$$\begin{array}{r} 3.4 \\ 36 \overline{) 124} \\ \underline{108} \\ 160 \end{array}$$

$$= 3.4$$

$$= 3 \text{ pigs}$$

$$\text{Maximum number of pigs} = 3$$

(Total for Question 7 is 4 marks)





8 The diagram shows a garden in the shape of a rectangle.

The scale of the diagram is 1 cm represents 2 m.

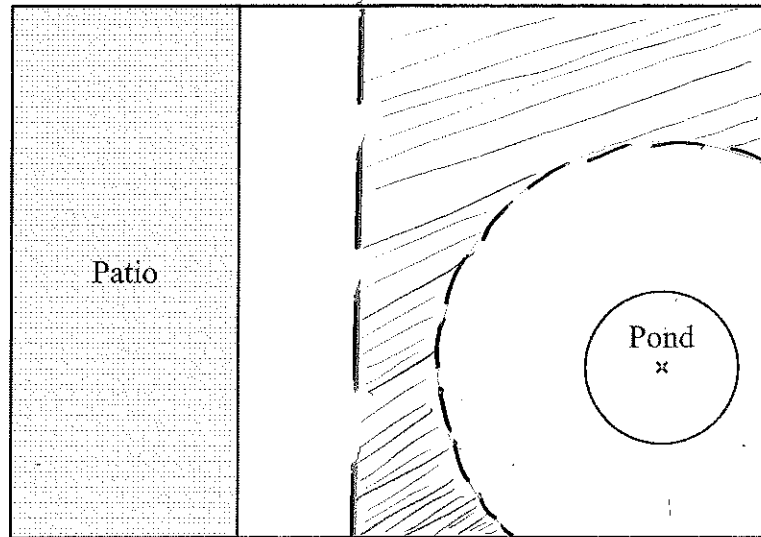

Scale: 1 cm represents 2 m

Irfan is going to plant a tree in the garden.

The tree must be

- more than 3 metres from the patio
- and** more than 6 metres from the centre of the pond.

On the diagram, shade the region where Irfan can plant the tree.

(Total for Question 8 is 3 marks)



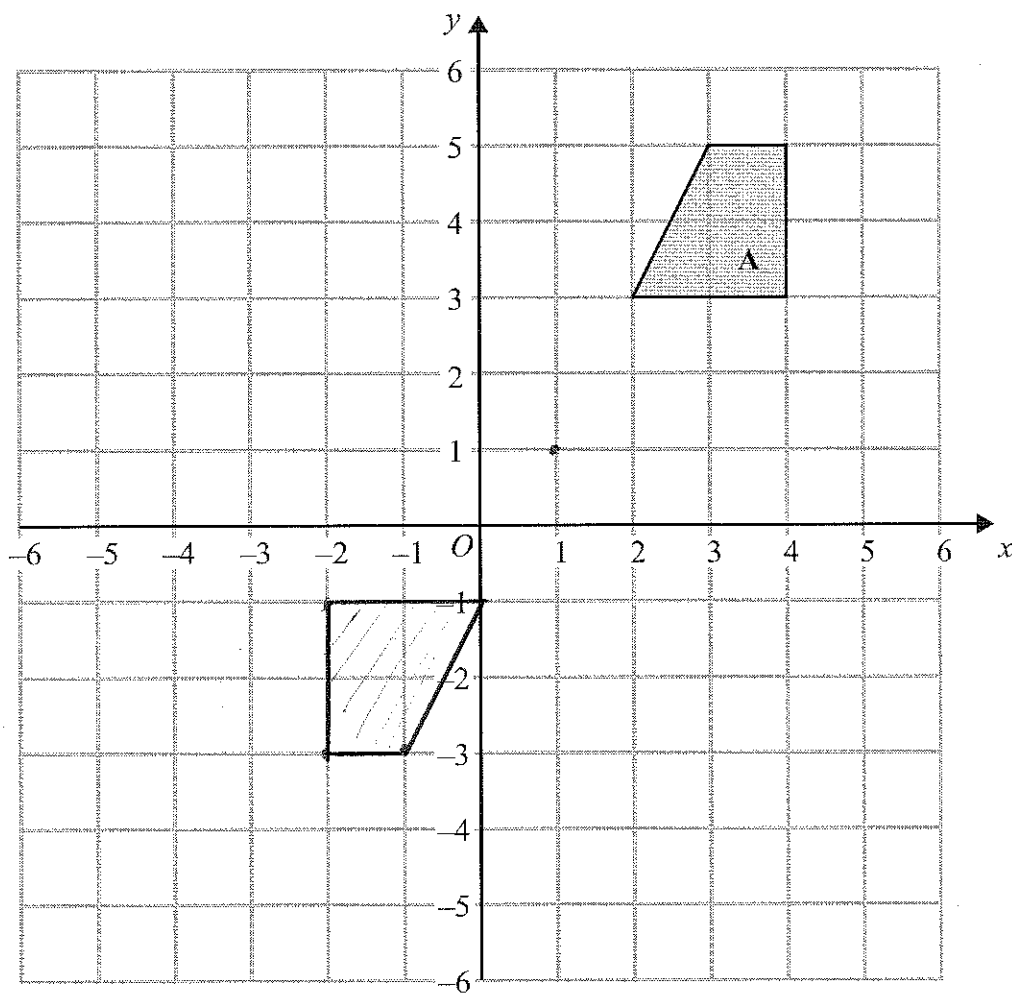

(a) On the grid, rotate shape A  $180^\circ$  about the point (1, 1).



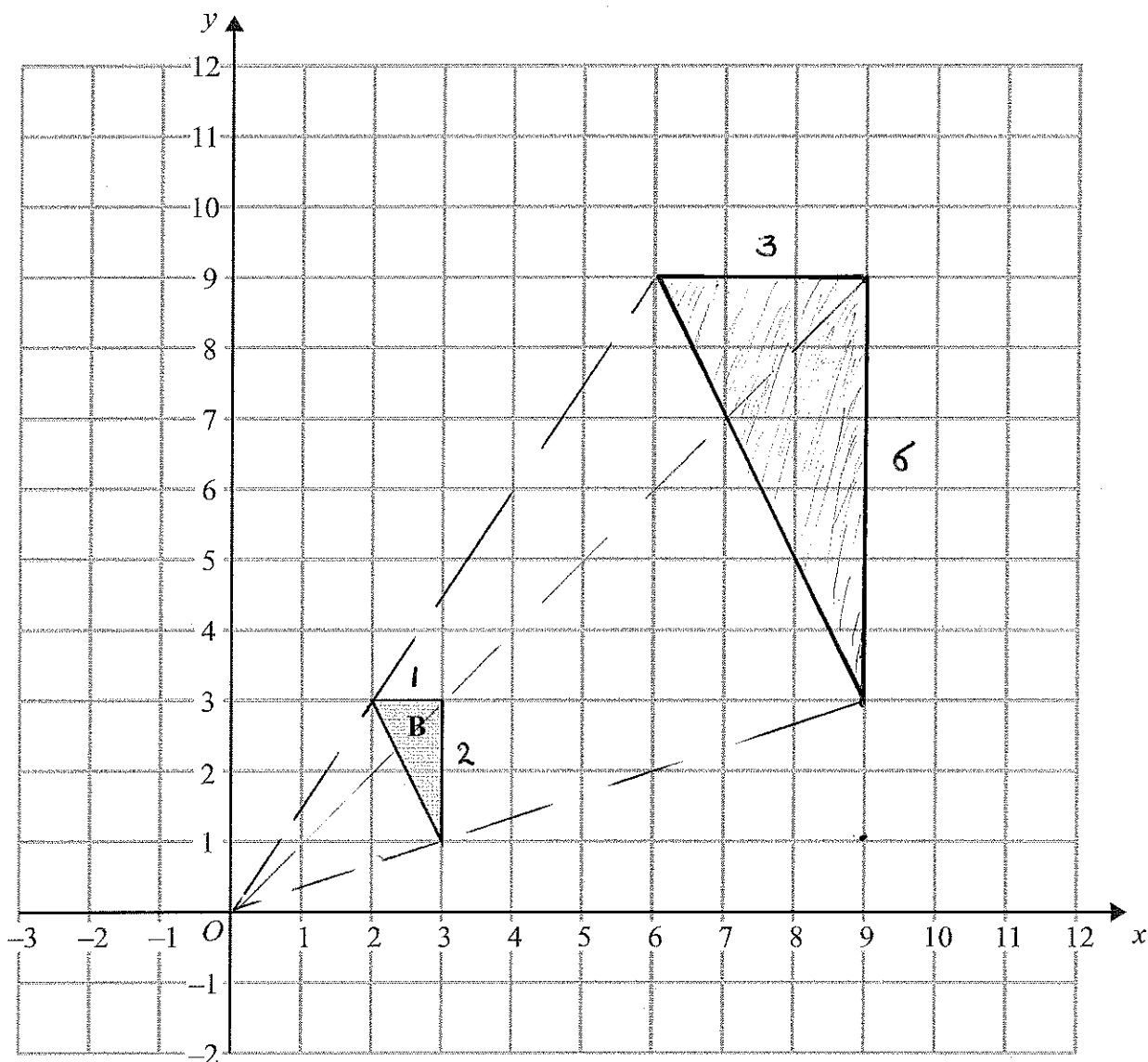

(b) On the grid, enlarge triangle **B** by scale factor 3, centre (0, 0).

(2)

(Total for Question 9 is 4 marks)

Coordinates of the vertices of B:

$(3, 1)$	$\times 3$	$(9, 3)$
$(3, 3)$	$\times 3$	$(9, 9)$
$(2, 3)$	$\times 3$	$(6, 9)$



\*10 Milk is sold in two sizes of bottle.

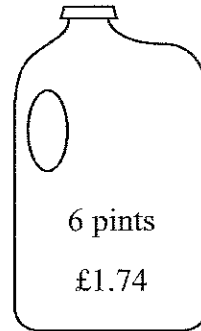
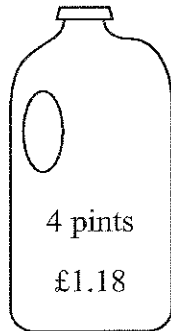

A 4 pint bottle of milk costs £1.18

A 6 pint bottle of milk costs £1.74

Which bottle of milk is the best value for money?

You must show all your working.

4 pints bottle

6 pints bottle

$$\begin{array}{l} 4 \text{ pints cost } \pounds 1.18 \\ (\times 3) \\ 12 \text{ pints cost } 1.18 \times 3 = \\ 12 \text{ pints cost } \pounds 3.54 \end{array}$$

$$\begin{array}{l} 6 \text{ pints cost } \pounds 1.74 \\ (\times 2) \\ 12 \text{ pints cost } 1.74 \times 2 \\ 12 \text{ pints cost } \pounds 3.48 \end{array}$$

6 pints bottle is the best value for money  
(6 pence cheaper)

(Total for Question 10 is 3 marks)



11

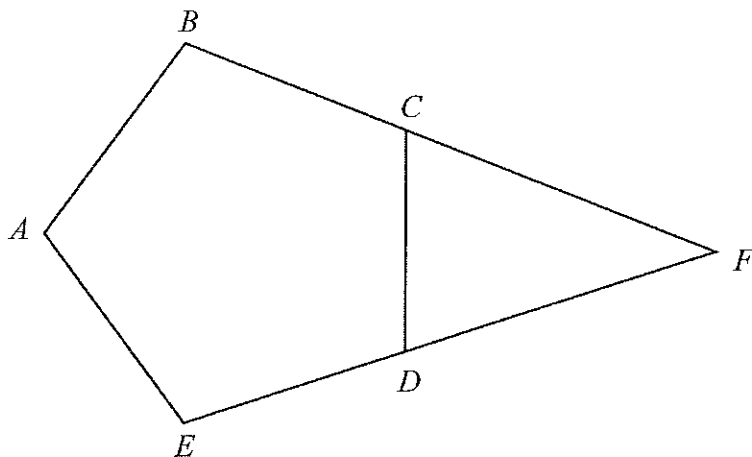
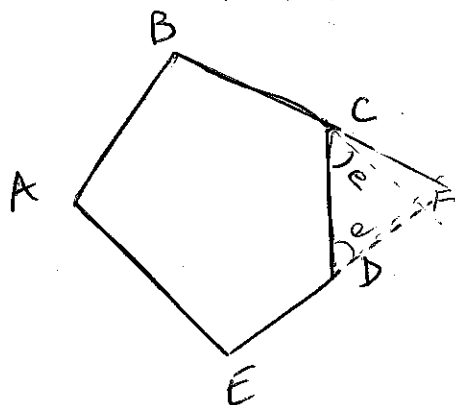

Diagram NOT accurately drawn

$ABCDE$  is a regular pentagon.  
 $BCF$  and  $EDF$  are straight lines.

Work out the size of angle  $CFD$ .  
 You must show how you got your answer.



$ABCDE$  regular pentagon.

$$\text{exterior angle } \hat{e} = \frac{360}{5}$$

$$\hat{e} = 72^\circ$$

$$\angle DCF = \angle FDC = 72^\circ$$

$$\begin{aligned} \angle CFD &= 180 - 72 - 72 \\ &= 180 - 144 \end{aligned}$$

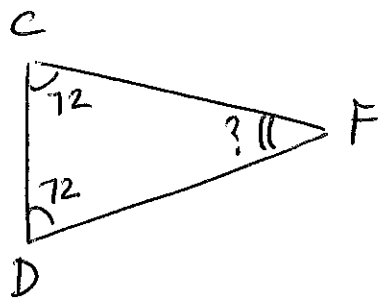

$$36^\circ$$

(Total for Question 11 is 3 marks)



12 You can change temperatures from °F to °C by using the formula

$$C = \frac{5(F - 32)}{9}$$

$F$  is the temperature in °F.

$C$  is the temperature in °C.

The minimum temperature in an elderly person's home should be 20°C.

Mrs Smith is an elderly person.

The temperature in Mrs Smith's home is 77°F.

\*(a) Decide whether or not the temperature in Mrs Smith's home is lower than the minimum temperature should be.

$$\text{When } F = 77^{\circ}\text{F} \quad C = \frac{5(77 - 32)}{9}$$

$$C = \frac{5 \times 45}{9} = 5 \times 5$$

$$C = 25^{\circ}\text{C}.$$

The  $t^{\circ}$  in Mrs Smith's home is higher than the minimum of 20°C.

(3)

(b) Make  $F$  the subject of the formula  $C = \frac{5(F - 32)}{9}$

$$9C = 5(F - 32)$$

$$\frac{9C}{5} = F - 32$$

$$\frac{9C}{5} + 32 = F$$

$$F = \frac{9}{5}C + 32$$

(3)

(Total for Question 12 is 6 marks)



\*13

**Competition**

a prize every 2014 seconds

In a competition, a prize is won every 2014 seconds.

Work out an estimate for the number of prizes won in 24 hours.  
You must show your working.

$$\begin{aligned} 24 \text{ hrs} &= 24 \times 60 \times 60 \text{ s} \\ &= 24 \times 36 \times 100 \text{ s} \\ &= 86400 \text{ seconds} \end{aligned}$$

$$\begin{array}{r} 24 \\ \times 36 \\ \hline 144 \\ 72 \\ \hline 864 \end{array}$$

$$\text{Number of prizes} = 86400 \div 2014$$

$$\begin{aligned} \text{Estimate number} &\approx 90000 \div 2000 \text{ (1sf)} \\ &\approx 45 \text{ Prizes} \end{aligned}$$

Answer in range 35-50 are correct.

(Total for Question 13 is 4 marks)



- 14 Emily is driving in France.  
She sees this sign.

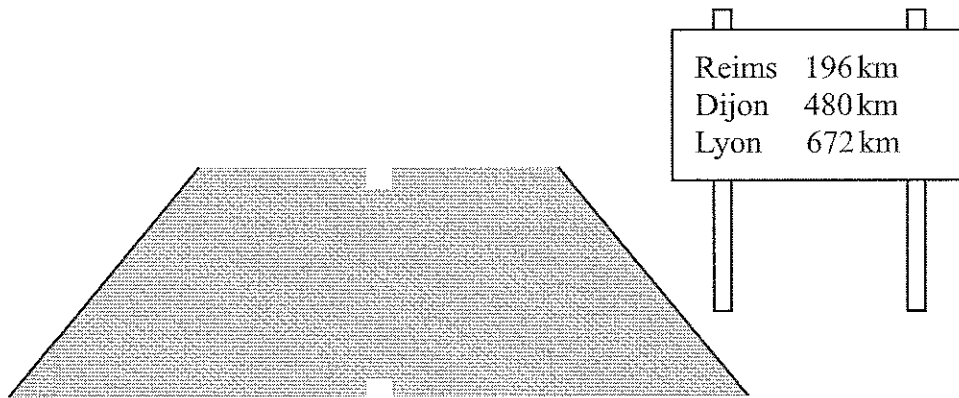

Emily is going to drive to Dijon.  
She plans to drive at an average speed of 50 miles per hour.

Work out how long it should take Emily to drive to Dijon.

$$S = \frac{D}{T} \quad \therefore T = \frac{D}{S} = \frac{\text{Distance}}{\text{Speed}}$$

Km : Miles

$$\text{box} \left( \begin{array}{l} 8 : 5 \\ 480 : 300 \end{array} \right) \times 60$$

Distance to Dijon is 300 miles

$$\therefore \text{Speed Time} = \frac{300}{50} = 6 \text{ hrs} \quad \dots \quad 6 \text{ hours}$$

(Total for Question 14 is 4 marks)





$$x = -1 \quad y = (-1)^2 - 2(-1) - 1 \\ = 1 + 2 - 1 = 2$$

$$x = 4 \rightarrow y = 4^2 - 2(4) - 1 = 7$$

$$x = 0 \rightarrow y = 0 - 0 - 1$$

$$x = 3 \rightarrow y = 3^2 - 2 \times 3 - 1 \\ = 2$$

15 (a) Complete the table of values for  $y = x^2 - 2x - 1$

x	-2	-1	0	1	2	3	4
y	7	2	-1	-2	-1	2	7

(2)

(b) On the grid, draw the graph of  $y = x^2 - 2x - 1$  for values of  $x$  from  $-2$  to  $4$

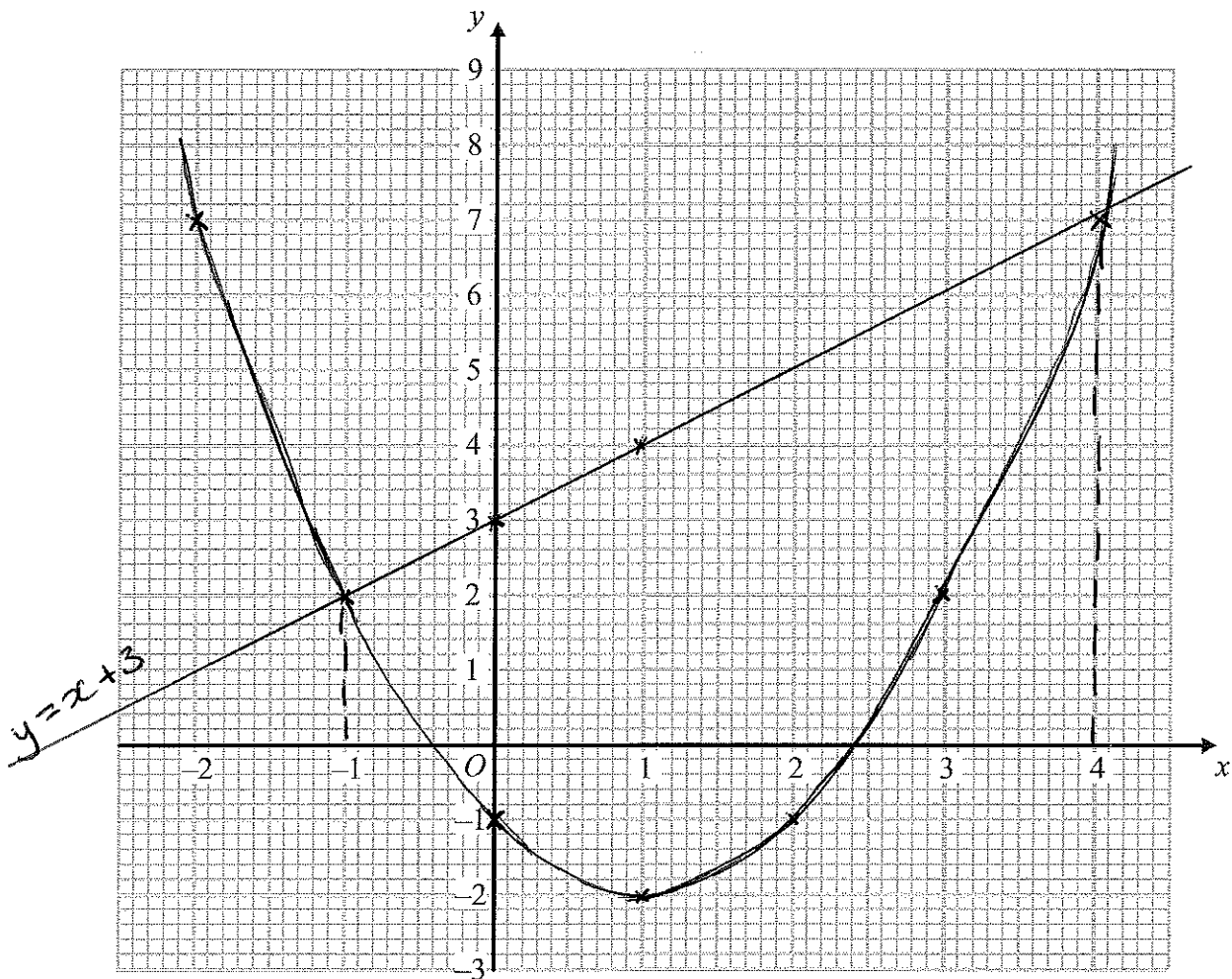

(2)

(c) Solve  $x^2 - 2x - 1 = x + 3$

$$x = -1 \quad (-1)^2 - 2(-1) - 1 = -1 + 3 \\ 2 = 2$$

$$x = 4 \quad (4)^2 - 2(4) - 1 = 4 + 3 \\ 7 = 7$$

$$\frac{-1}{-1} \quad \frac{4}{4}$$

(2)

(Total for Question 15 is 6 marks)



16 Colin took a sample of 80 football players.

He recorded the total distance, in kilometres, each player ran in the first half of their matches on Saturday.

Colin drew this box plot for his results.

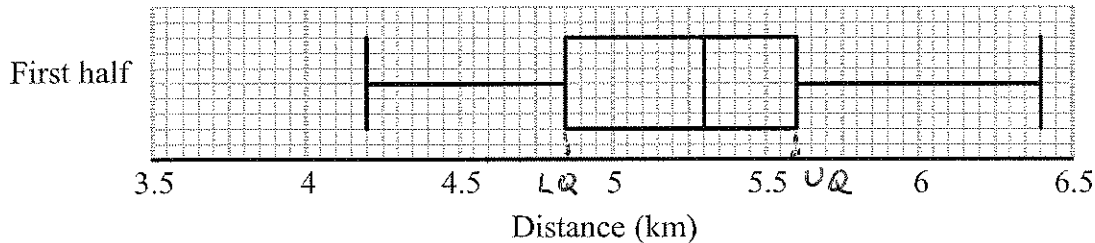

(a) Work out the interquartile range.

$$IQR = UQ - LQ = 5.6 - 4.85 = 0.75$$

$$0.75 \text{ km}$$

There were 80 players in Colin's sample.

(b) Work out the number of players who ran a distance of more than 5.6 km.

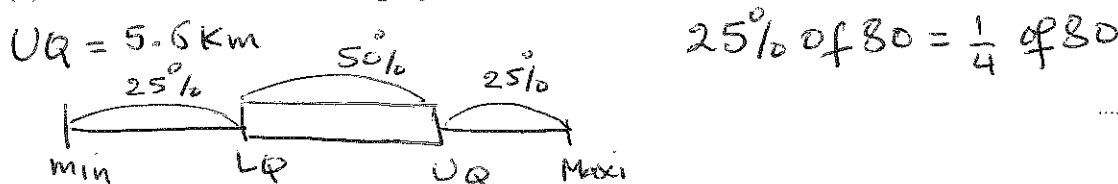

Colin also recorded the total distance each player ran in the second half of their matches.

He drew the box plot below for this information.

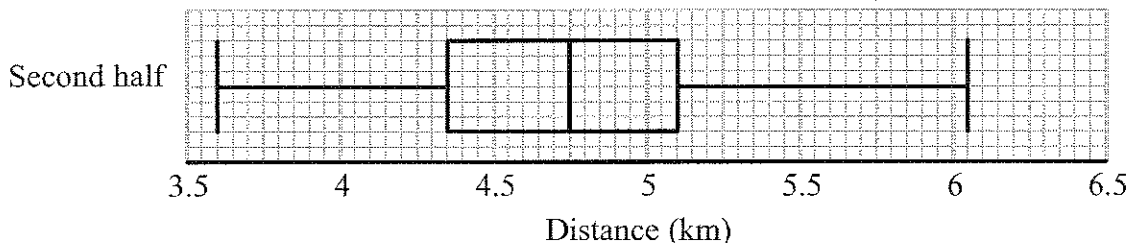

(c) Compare the distribution of the distances run in the first half with the distribution of the distances run in the second half.

$$IQR (\text{second half}) = 5.1 - 4.35 = 0.75 \text{ km}$$

$$IQR (2^{\text{nd}} \text{ Half}) = IQR (1^{\text{st}} \text{ Half})$$

Median ( $1^{\text{st}}$  Half = 5.3 km) Higher than the Median ( $2^{\text{nd}}$  Half = 4.75)

$$(5.3 \text{ km} > 4.75 \text{ km})$$

(Total for Question 16 is 6 marks)



17 (a) Write down the value of  $10^0$

$$10^0 = 10^{-1+1} = 10^{-1} \times 10^1 = \frac{10^1}{10^1}$$

1

(1)

(b) Write down the value of  $10^{-2}$

$$10^{-2} = \frac{1}{10^2} = \frac{1}{100} = 0.01$$

0.01

(1)

(c) Write these numbers in order of size.  
Start with the smallest number.

$2.73 \times 10^3$

$27.3 \times 10^{-3}$

$273 \times 10^2$

$0.00273$

$2730$

$0.0273$

$27300$

$0.00273$

$$0.00273; 27.3 \times 10^{-3}; 2.73 \times 10^3; 273 \times 10^2$$

(2)

(Total for Question 17 is 4 marks)

0.00273  
0.0273  
2730  
27300

S  
↓  
L



18 Solve the simultaneous equations

$$\begin{cases} 4x + y = 25 \\ x - 3y = 16 \end{cases}$$

$$3 \times \begin{cases} 4x + y = 25 \\ x - 3y = 16 \end{cases} \times 3$$

$$\begin{cases} 12x + 3y = 75 & (1) \\ x - 3y = 16 & (2) \end{cases}$$

(1) + (2)

$$\underline{13x = 91}$$

$$x = 91 \div 13$$

$$x = 7$$

$x = 7$  will give  $4 \times 7 + y = 25$   
 $y = 25 - 28$   
 $= -3$

$x = 7$

$y = -3$

(Total for Question 18 is 3 marks)



19 The diagram shows a straight line,  $L_1$ , drawn on a grid.

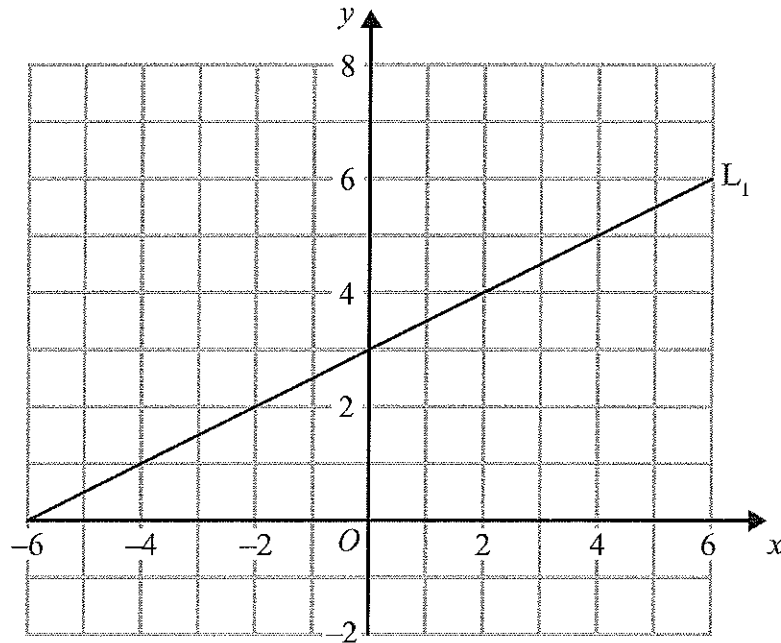

A straight line,  $L_2$ , is parallel to the straight line  $L_1$  and passes through the point  $(0, -5)$ .

Find an equation of the straight line  $L_2$ .

$L_2$  Parallel to  $L_1 \therefore$  Gradient  $L_2 =$  Gradient  $L_1$ .

$$\text{Gradient} = \frac{6-3}{6-0} = \frac{3}{6} = \frac{1}{2}$$

$$L_2: y = \frac{1}{2}x + c$$

Passes through  $(0, -5) \therefore -5 = \frac{1}{2} \times 0 + c$   
 $c = -5$

$$y = \frac{1}{2}x - 5$$

(Total for Question 19 is 3 marks)



20 Steve has a photo and a rectangular piece of card.

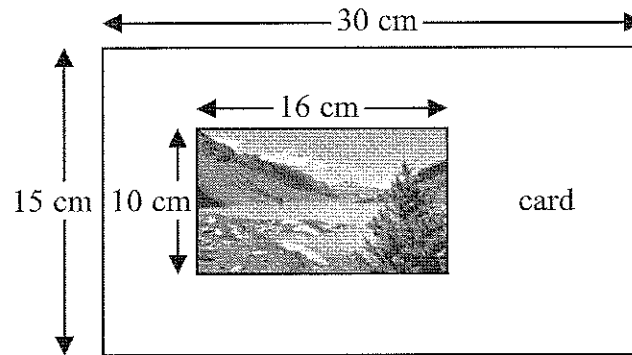
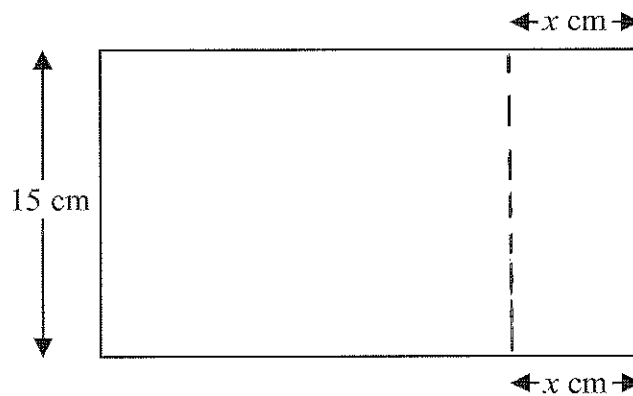

Diagram NOT accurately drawn

The photo is 16 cm by 10 cm.  
The card is 30 cm by 15 cm.

Steve cuts the card along the dotted line shown in the diagram below.



Steve throws away the piece of card that is 15 cm by  $x$  cm.  
The piece of card he has left is mathematically similar to the photo.

Work out the value of  $x$ .

16

10

15

$30 - x$

$$10 \times (SF) = 15 \therefore SF = \frac{15}{10} = \frac{3}{2}$$

$$16 \times \frac{3}{2} = 30 - x$$

$$24 = 30 - x \therefore$$

$$x = 30 - 24 = 6$$

6

(Total for Question 20 is 3 marks)



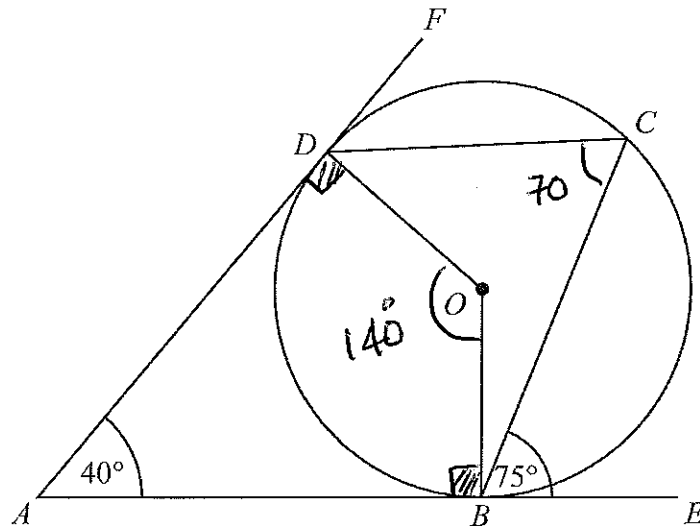

Diagram NOT  
accurately drawn

$B$ ,  $C$  and  $D$  are points on the circumference of a circle, centre  $O$ .  
 $ABE$  and  $ADF$  are tangents to the circle.

Angle  $DAB = 40^\circ$

Angle  $CBE = 75^\circ$

Work out the size of angle  $ODC$ .

$$(a) \quad \widehat{DOB} = 180 - 40 = 140^\circ \quad \therefore \widehat{DCB} = 140 \div 2 = 70^\circ$$

$$(b) \quad \widehat{OBC} = 90 - 75^\circ = 15^\circ \quad \therefore \widehat{ABC} = 90 + 15 = 105^\circ$$

(c) In the quadrilateral  $ADCB$ :

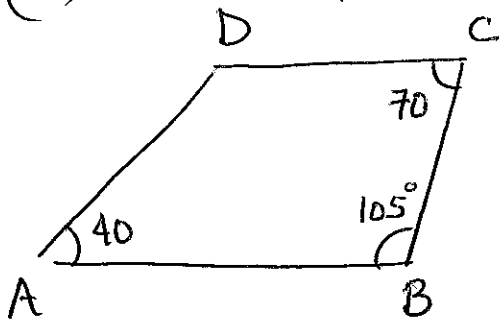

$$\widehat{ADC} = 360 - (70 + 40 + 105)$$

$$\widehat{ADC} = 145^\circ$$

55°

(Total for Question 21 is 3 marks)

$$(d) \quad \widehat{ODC} = \widehat{ADC} - \widehat{ADO}$$

$$= 145 - 90$$

$$\widehat{ODC} = 55^\circ$$



22 (a) Simplify  $(3x^2y^4)^3$

$$3^3 x^{2 \times 3} y^{4 \times 3}$$

$$\frac{27x^6y^{12}}{(2)}$$

(b) Simplify  $\frac{x^2 - 9}{2x^2 + 5x - 3}$

$$\begin{aligned} 2x^2 + 5x - 3 &= 2x^2 + 6x - x - 3 \\ &= 2x(x+3) - (x+3) \\ &= (x+3)(2x-1) \end{aligned}$$

$$\frac{x^2 - 9}{2x^2 + 5x - 3} = \frac{(x+3)(x-3)}{(x+3)(2x-1)}$$

$$\frac{x-3}{2x-1} \quad (3)$$

(Total for Question 22 is 5 marks)





23 Yvonne has 10 tulip bulbs in a bag.

7 of the tulip bulbs will grow into red tulips.

3 of the tulip bulbs will grow into yellow tulips.

Yvonne takes at random two tulip bulbs from the bag.

She plants the bulbs.

(a) Complete the probability tree diagram.

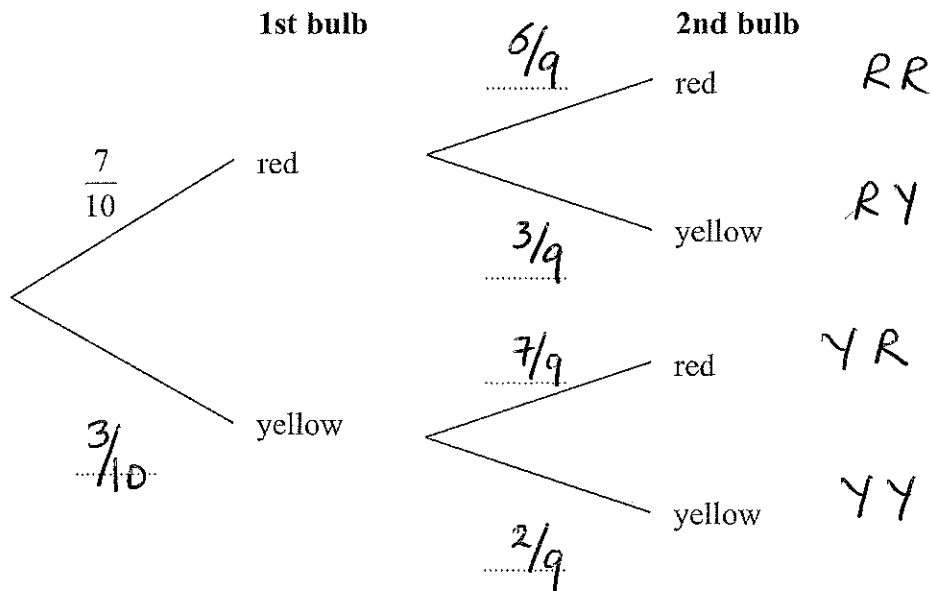

(b) Work out the probability that at least one of the bulbs will grow into a yellow tulip.

(RY) or (YR) or (YY).

$$\frac{7}{10} \times \frac{3}{9} + \frac{3}{10} \times \frac{7}{9} + \frac{3}{10} \times \frac{2}{9}$$

$$\frac{21}{90} + \frac{21}{90} + \frac{6}{90} = \frac{48}{90}$$

$$\frac{48}{90}$$

(Total for Question 23 is 5 marks)



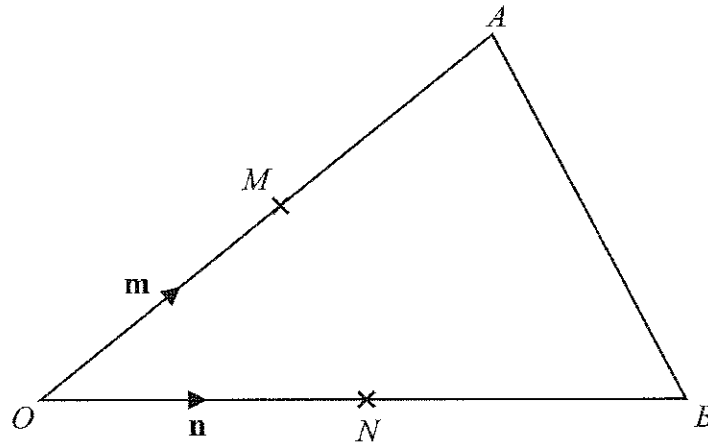

Diagram NOT  
accurately drawn

$OAB$  is a triangle.

$M$  is the midpoint of  $OA$ .

$N$  is the midpoint of  $OB$ .

$$\vec{OM} = \mathbf{m}$$

$$\vec{ON} = \mathbf{n}$$

$$\vec{OA} = 2\vec{OM} = 2\mathbf{m}$$

$$\vec{OB} = 2\vec{ON} = 2\mathbf{n}$$

Show that  $AB$  is parallel to  $MN$ .

$$\vec{AB} = \vec{AO} + \vec{OB} = -2\mathbf{m} + 2\mathbf{n} = 2\mathbf{n} - 2\mathbf{m} = 2(\mathbf{n} - \mathbf{m})$$

$$\vec{MN} = \vec{MO} + \vec{ON} = -\mathbf{m} + \mathbf{n} = \mathbf{n} - \mathbf{m}$$

$$\begin{cases} \vec{AB} = 2(\mathbf{n} - \mathbf{m}) \\ \vec{MN} = \mathbf{n} - \mathbf{m} \end{cases} \therefore \boxed{\vec{AB} = 2\vec{MN}}$$

$\vec{AB}$  is parallel to  $\vec{MN}$ .

(Total for Question 24 is 3 marks)



25 (a) Rationalise the denominator of  $\frac{12}{\sqrt{3}}$

$$\frac{12\sqrt{3}}{\sqrt{3}\sqrt{3}} = \frac{12\sqrt{3}}{\sqrt{9}} = \frac{12\sqrt{3}}{3} = 4\sqrt{3}$$

$$\frac{4\sqrt{3}}{\dots}$$

(2)

(b) Work out the value of  $(\sqrt{2} + \sqrt{8})^2$

$$(\sqrt{2})^2 + (\sqrt{8})^2 + 2 \times \sqrt{2} \times \sqrt{8}$$

$$2 + 8 + 2\sqrt{2 \times 8}$$

$$10 + 2\sqrt{16}$$

$$10 + 2 \times 4$$

$$18$$

$$\frac{18}{\dots}$$

(2)

(Total for Question 25 is 4 marks)



26 The diagram shows part of a sketch of the curve  $y = \sin x^\circ$ .

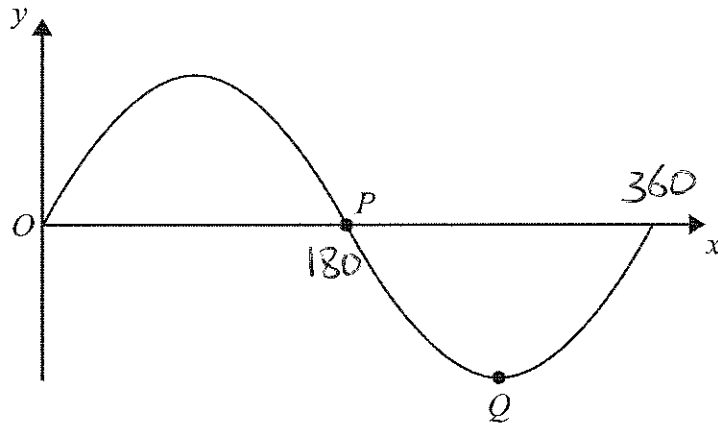

(a) Write down the coordinates of the point  $P$ .

( 180 , 0 )

(b) Write down the coordinates of the point  $Q$ .

( 270 , -1 )

Here is a sketch of the curve  $y = a \cos bx^\circ + c$ ,  $0 \leq x \leq 360$

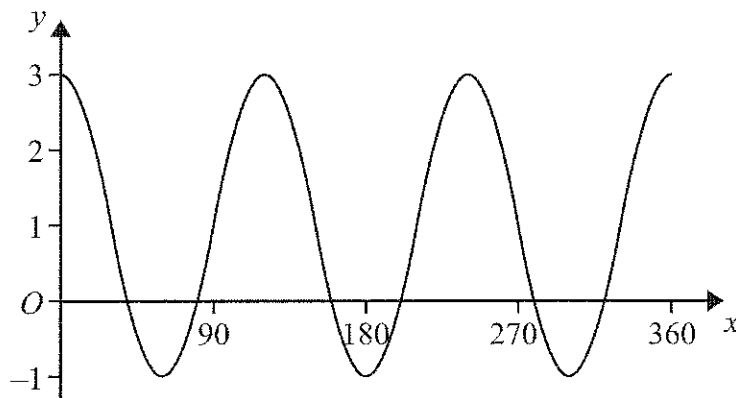

(c) Find the values of  $a$ ,  $b$  and  $c$ .

$\cos x \rightarrow \cos bx$  stretch  $x$  axis  $b=3$

$a = 2$

$\cos bx \rightarrow a \cos bx$  stretch  $y$  axis  $a=2$

$b = 3$

$a \cos bx \rightarrow a \cos bx + c$  shift on  $y$  axis  $+1$

$c = +1$

(3)

(Total for Question 26 is 5 marks)

TOTAL FOR PAPER IS 100 MARKS

